

Thermal Imaging, Power Quality and Harmonics

Authors: Matthew A. Taylor and Paul C. Bessey of AVO Training Institute

Executive Summary

Infrared (IR) thermal imaging (thermography) is an effective troubleshooting tool, but many electricians who use IR cameras to spot overheated wires, connections and components may not be knowledgeable about the full range of causes that can cause such overheating, in particular issues of power quality and harmonics.

Thermal Imaging for Troubleshooting

Thermography is rapidly becoming a valuable method for detecting problems in electrical systems.



Fluke TiX500 Infrared Camera

Excess heat is a common byproduct of many well-understood electrical malfunctions such as loose or corroded connections or bad motor bearings. When an IR image is compared to a regular photographic image (most IR cameras will show you both), many electrical problems become quite obvious, as shown in the example below where one of the three fuses is much hotter than the others.

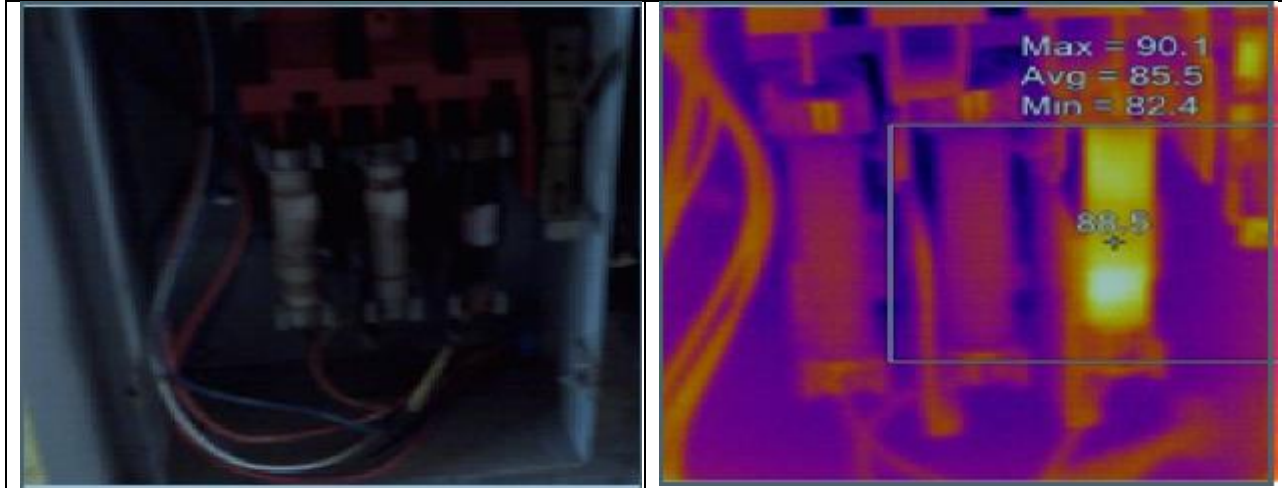

Visible-Light Photo (left) and IR Photo (right) Showing Hot Fuse in One Phase

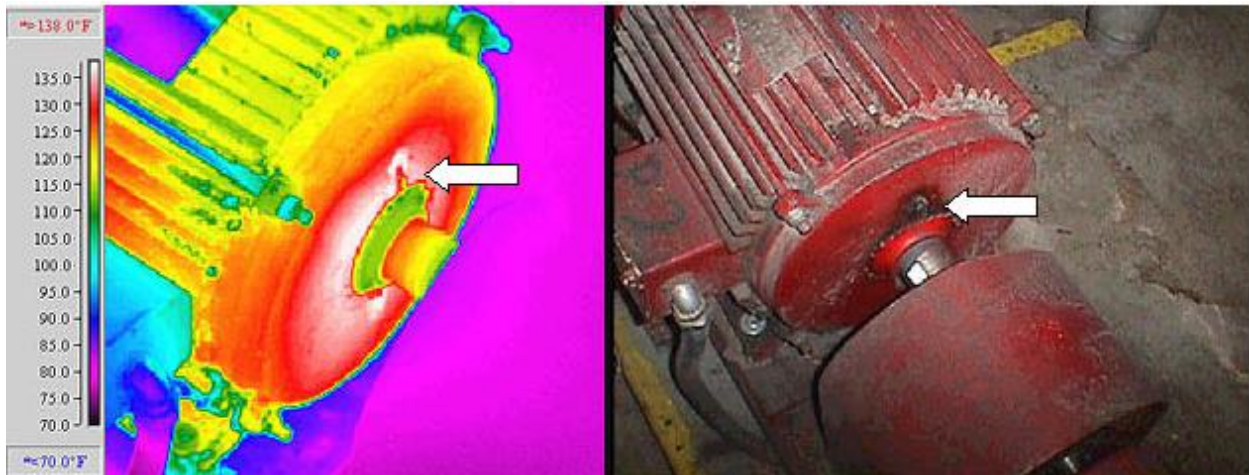

Possible Bad Bearing

Thermal imaging can detect an issue in an electrical system before that issue significantly degrades the performance of the system, or before the issue gives rise to a safety problem such as the risk of fire.

An electrician who performs routine periodic thermal inspections with an IR camera can avoid most catastrophic failures and keep the plant running smoothly. It is a good practice to keep a historical record of thermal images of various components, wires and connections taken under repeatable conditions, so that any changes in the heat signatures of these components will alert the electrician to the need for some preemptive action to correct the issue. Often this preemptive action will involve something simple like re-torquing lug nuts, cleaning corrosion off of terminals or replacing an undersized conductor with a properly rated one.

An additional advantage of thermography is that it allows the electrician to detect a problem while standing off some safe and convenient distance from the item being tested. For example, measuring

the temperature of transformers on utility poles while standing on the ground with an IR camera is much easier and safer than climbing poles.

It may not be generally recognized by many plant electricians that there are whole classes of problems that show up as excess heat on an IR camera that are not due to high resistance connections or bad bearings. These problems are due to “power quality” issues and “harmonics”. This paper addresses these more complex issues.

Power Factor

When the current is in-phase with the voltage then the maximum power is transferred to the load and the power factor is equal to one. Many facilities have a preponderance of inductive loads such as motors. These loads, if uncompensated, will cause the current to be out of phase with the voltage, thereby reducing the power factor. When the current drifts out of phase with the voltage, the motors must draw more current in order to maintain the same work output. The extra current flowing through the conductors manifests as extra heat. An increase in the temperature of the conductors might be detectable with an IR camera, if compared with historical images taken under repeatable conditions.

Banks of capacitors are often used to bring the current back into phase with the voltage, thereby bringing the power factor back close to one and reducing electric bills.

Harmonics Fundamentals

Consider the following simple electrical system where the “Source” block represents single phase electrical service provided by the power company, E_s represents the source voltage, Z_s represents the source impedance and Z_L represents the load impedance. If the source impedance was zero (the ideal, but impossible case) then nothing one could do on the load side could distort the source voltage (E_s).

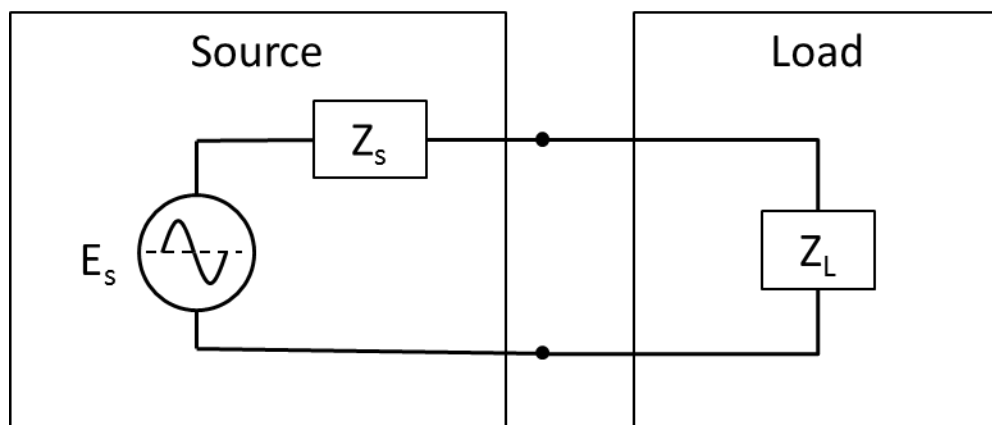

Single Phase Electrical Service Driving a Single Load

The voltage supplied by the power company is intended to be undistorted by harmonics, which means it is purely sinusoidal. In an ideal system driving a resistive load, the current is also sinusoidal.

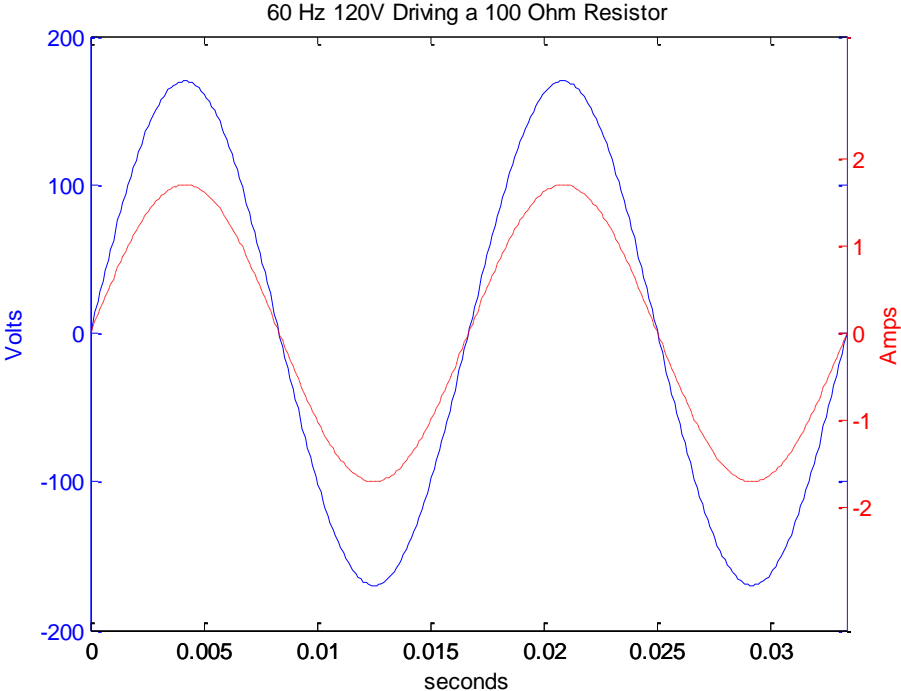

Purely Sinusoidal (Undistorted) Voltage and Current

The plot above represents the voltage across and the current through a 100 ohm load resistor, plotted over time. If, instead of plotting the voltage and current versus time, you leave time out of it and plot the current versus the voltage, the resultant plot is a straight line, as shown below. This is just a plot of Ohm's Law, $E = IR$ with $R = 100$ ohms. Resistive loads are called "linear" due to the fact that this V-I plot is a straight line.

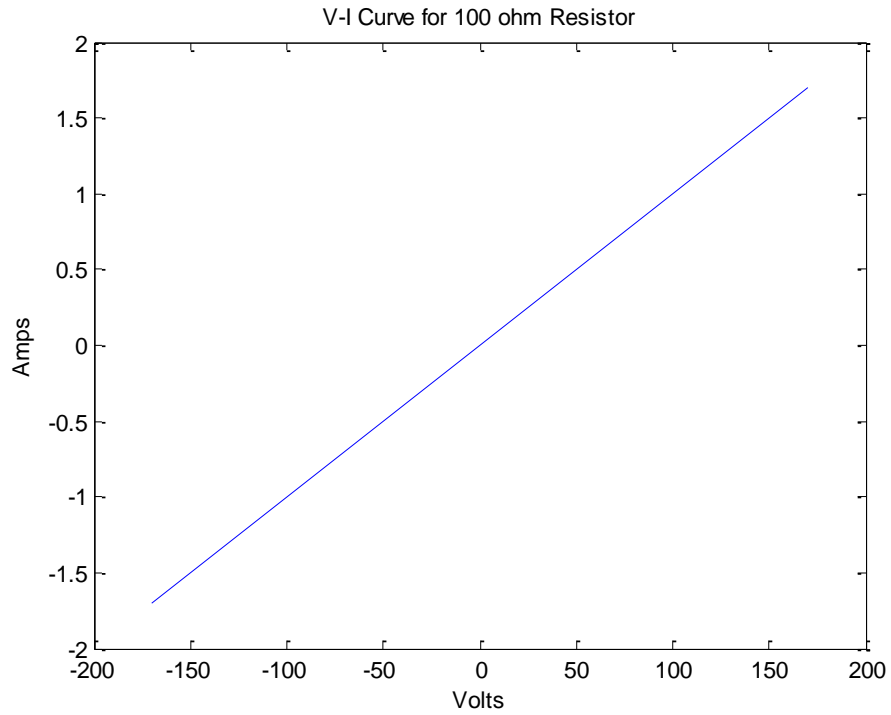

V-I Curve for Linear Load

Semiconductor loads such as computers, switching power supplies, electronic ballasts and variable frequency motor drives are "non-linear" loads, which results in a distorted sine wave. The following plot is an example of a distorted sine wave, which could represent the voltage across and/or the current through a load impedance.

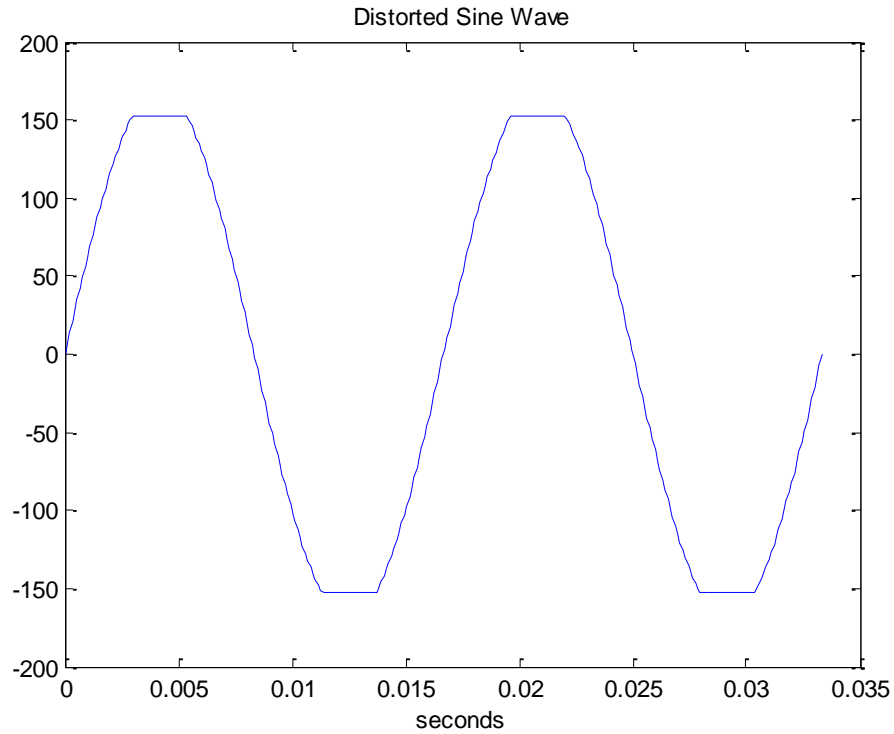

Distorted Sine Wave (Voltage or Current)

This common form of distortion is called “clipping” because the tops and bottoms of the sine waves are clipped off. The resulting V-I curve (see plot below) is no longer a straight line (the left and right sides of the line level out), so we say that the load is “non-linear”. This is just one type (out of many types) of distortion.

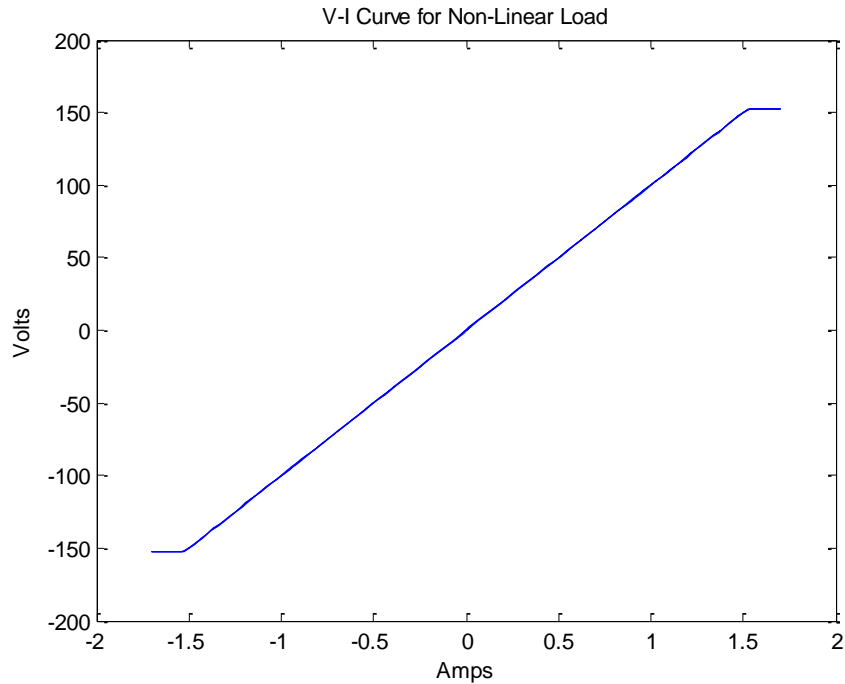

V-I curve for a Non-Linear Load

A Frenchman named Fourier figured out (in the early 1800's) that you can create any continuous periodic signal with frequency f (such as our clipped sine wave) by adding together a series of pure sine waves whose frequencies are integer multiples of f . The main frequency f is called the "fundamental" frequency. The second harmonic is the sine wave with frequency $2f$, the third harmonic has frequency $3f$, etc.ⁱ

When sine waves are distorted symmetrically about their average values (like our clipped signal) then they are composed of odd harmonics only. Most often this is the case so that odd harmonics are much more commonly observed than even harmonics. Below is an example of how the fundamental and two odd harmonics might add up for an arbitrarily chosen distorted voltage or current waveform shape.

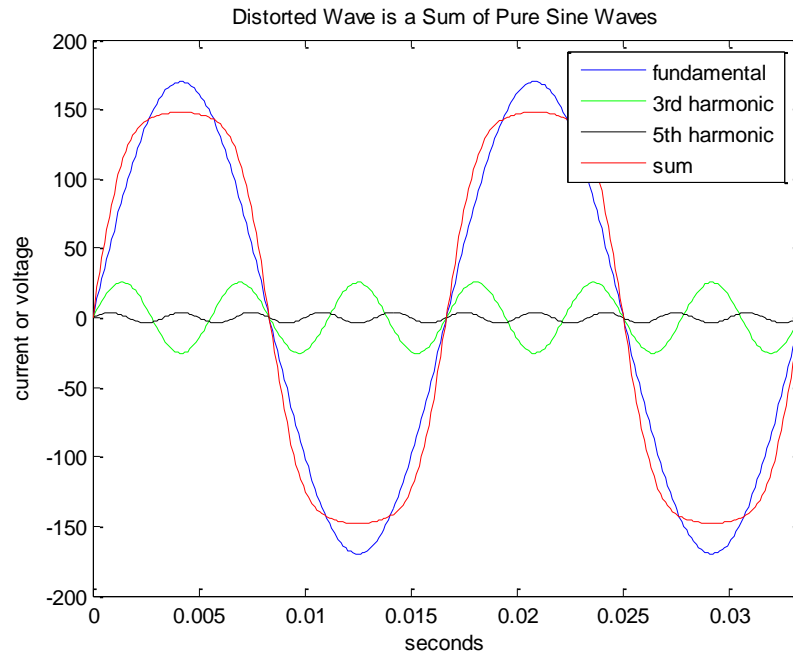

Distorted Wave Composed of a Sum of Harmonics

These harmonics are a power quality problem because electrical systems and components are (typically) designed for 60 Hertz (or 50 Hertz in some countries) and several undesirable things may happen when they are subjected to 180 Hertz (the 3rd harmonic), 300 Hertz (the 5th harmonic) and higher frequencies.

We tend to think of the resistance of conductors as independent of frequency. However, that is not strictly true. At higher frequencies (or higher harmonics of the fundamental frequency) the current moves away from the center towards the skin of the conductor. This “skin effect”, since it crowds more current in a smaller cross-sectional area, results in increased conductor resistance at higher frequencies. Increased resistance results in more power lost as heat, potentially contributing to overheating of conductors, terminations and components. Thermography may provide our first clue that we are having such problems.

The Method of Symmetrical Components

In order to analyze three-phase electrical systems we’re going to need to understand some mathematics developed by a man named Fortescue in the early 1900’s called the “Method of Symmetrical Components”.ⁱⁱ

Consider the three-phase Y system shown below which consists of some three-phase loads (Z_{AB} , Z_{AC} , and Z_{BC}) and some single-phase loads (Z_a , Z_b and Z_c).

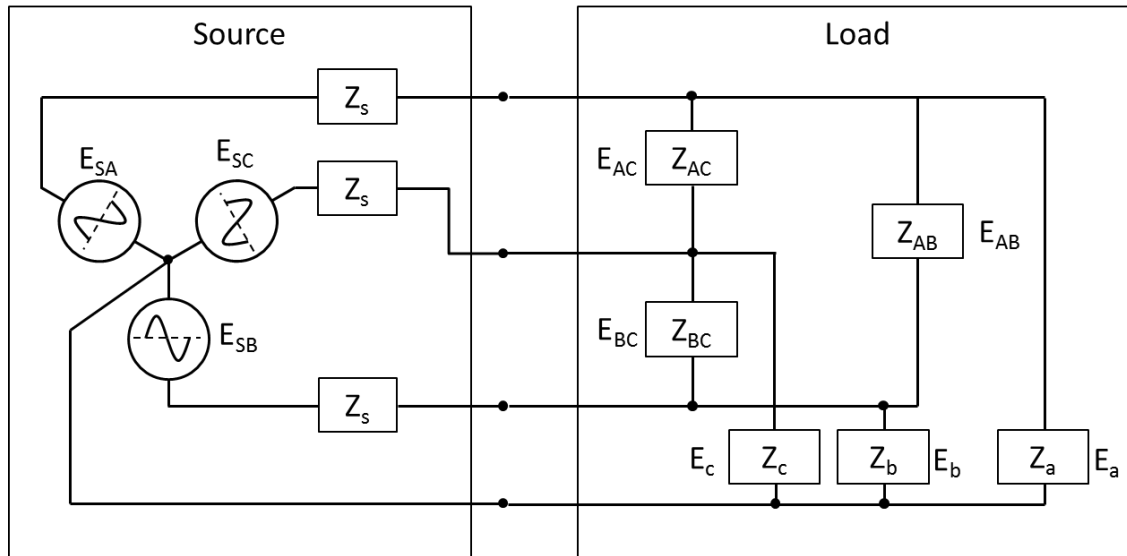

Three-Phase Electrical System

A “balanced” three-phase system with no harmonics has E_a , E_b and E_c equal in amplitude and 120 degrees apart, and the same goes for the respective currents. This is not true for an unbalanced system and in real life all systems are to some extent unbalanced. Unbalanced current draws give rise to unbalanced voltages and phase angles between phases that are not exactly 120 degrees. This can cause problems that will often show up on IR images.

To make analysis of unbalanced systems easier, the method of symmetrical components is used. This method can be elegantly expressed using the branch of mathematics that deals with vectors and matrices, called “linear algebra”. If you are not familiar with linear algebra, feel free to skip the next few paragraphs.

Here’s how it works. Unbalanced phasors representing the complex voltages (E_a , E_b and E_c) or the complex currents (I_a , I_b and I_c) can be represented as the vector sum of three sets of balanced phasors. These three sets of balanced phasors are called the zero sequence, positive sequence and negative sequence components, represented in the following equations by the subscripts “0”, “1” and “2”. Let’s concentrate on the voltage equations first. ⁱⁱ

$$E_{abc} = \begin{bmatrix} E_a \\ E_b \\ E_c \end{bmatrix} = \begin{bmatrix} E_{a,0} \\ E_{b,0} \\ E_{c,0} \end{bmatrix} + \begin{bmatrix} E_{a,1} \\ E_{b,1} \\ E_{c,1} \end{bmatrix} + \begin{bmatrix} E_{a,2} \\ E_{b,2} \\ E_{c,2} \end{bmatrix}$$

The rightmost 3 vectors in the equation above are the zero sequence, positive sequence and negative sequence vectors.

We define the operator α (used to shift the phases of the component phasors so that they are 120 degrees apart) as:

$$\alpha = e^{j(2/3)\pi}$$

The 3 components of the zero sequence vector are of equal amplitude and in-phase, so the zero sequence vector simplifies to:

$$\begin{bmatrix} E_{a,0} \\ E_{b,0} \\ E_{c,0} \end{bmatrix} = \begin{bmatrix} E_0 \\ E_0 \\ E_0 \end{bmatrix}$$

The 3 positive sequence phasors are of the same amplitude (call that amplitude E_1) but are 120 degrees apart from each other. Multiplying by α imposes a 120 degree phase shift, and multiplying by α^2 imposes a 240 degree phase shift, so

$$\begin{bmatrix} E_{a,1} \\ E_{b,1} \\ E_{c,1} \end{bmatrix} = \begin{bmatrix} E_1 \\ \alpha^2 E_1 \\ \alpha E_1 \end{bmatrix}$$

The 3 negative sequence vectors are of the same magnitude (call that amplitude E_2) but the sequence is reversed, so

$$\begin{bmatrix} E_{a,2} \\ E_{b,2} \\ E_{c,2} \end{bmatrix} = \begin{bmatrix} E_2 \\ \alpha E_2 \\ \alpha^2 E_2 \end{bmatrix}$$

Then if we define $E_{012} = \begin{bmatrix} E_0 \\ E_1 \\ E_2 \end{bmatrix}$ and $A = \begin{bmatrix} 1 & 1 & 1 \\ 1 & \alpha^2 & \alpha \\ 1 & \alpha & \alpha^2 \end{bmatrix}$, we can express our decomposition into symmetrical components quite compactly as AE_{012} such that:

$$E_{abc} = AE_{012}$$

E_{012} is a complex 3-vector representing the amplitudes and phase shifts of the constellations of the 3 symmetrical components and E_{abc} is a complex 3-vector representing the (balanced or unbalanced) phasors of the actual voltages. In real life, the 3 complex numbers in the vector E_{abc} may have been obtained by an electrician using a power quality meter to measure the voltage phasors off of the Y-configured secondary of a 3 phase transformer.

If we have measurements of the 3 phasors from a 3 phase transformer and wish to compute the magnitude of the zero, positive and negative sequence components, then we can do it using the inverse of the A matrix.

$$E_{012} = A^{-1}E_{abc}$$

where $A^{-1} = \frac{1}{3} \begin{bmatrix} 1 & 1 & 1 \\ 1 & \alpha & \alpha^2 \\ 1 & \alpha^2 & \alpha \end{bmatrix}$

The math applies in analogous manner to the currents, so the equivalent current formulation is

$$I_{abc} = AI_{012} \quad \text{and} \quad I_{012} = A^{-1}I_{abc}$$

If the legs of the original three-phase system are sequenced as A-B-C, then the three equal positive sequence phasors will also be sequenced A-B-C, but the negative sequence phasors will be sequenced A-C-B. The zero sequence phasors are all in-phase. A balanced system with no harmonics will have only the positive sequence vectors. In other words, the magnitude of the negative sequence vectors and the zero sequence vectors will be zero.

The following plot shows the zero, positive and negative sequence component phasors (the bottom row of the figure) for some unbalanced system (the top row of the figure). Each color phasor in the top plot is the vector sum of the same color in the lower 3 plots. The zero-sequence plot shows only one phasor but that's because all 3 phasors are in phase and therefore lie right on top of each other on the plot. All of these phasor diagrams rotate counterclockwise over time (one complete rotation in $1/60^{\text{th}}$ of a second if the frequency is 60 Hertz).

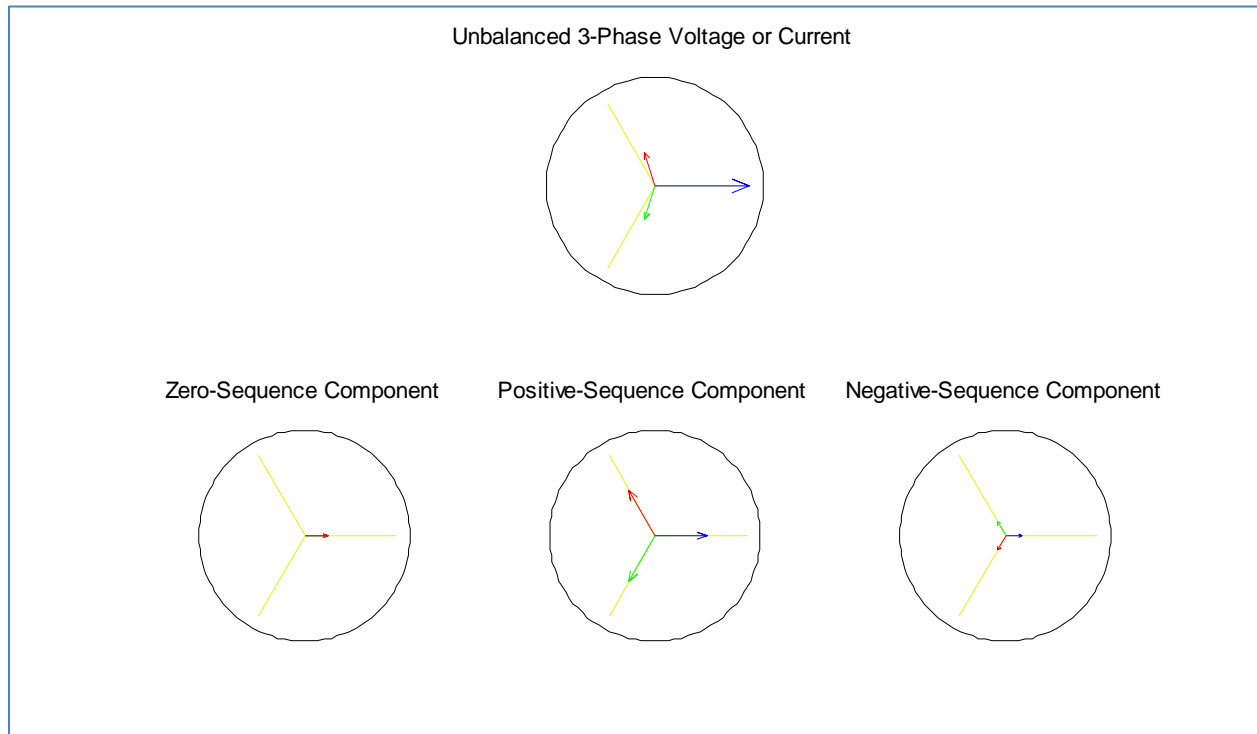

Method of Symmetrical Components

You can experiment with plots like this using a free, downloadable learning tool called the “Power Quality Teaching Toy” created by Alex McEachern at Power Standards Laboratory. It can be used to explore the method of symmetrical components, harmonics and power quality issues. It can be downloaded from <http://www.powerstandards.com/PQTeachingToyIndex.php>.

In the case of a three-phase motor being driven by unbalanced voltages, the negative sequence phasors, because they are sequenced opposite to the positive sequence phasors, will exert a motor torque in the opposite direction from the motor rotation. In other words, they will work against the motor. This wasted power working against the motor gets dissipated as excess heat which may be detected with an IR camera. Therefore thermal imaging may be a good troubleshooting tool to indicate the presence of an unbalanced load condition on the secondary of a 3-phase transformer.

A perfectly balanced 3-phase Y system will have no current on the neutral wire. In an unbalanced system, the zero sequence currents will add in-phase on the neutral wire to cause excess heat on that wire which may be detected with an IR camera.

The symmetrical component phasors are valid only for a single frequency at a time, so if there are harmonics then the plot for each harmonic frequency must be considered independently. For example, let us consider the third harmonic. The third harmonic poses particular problems in a three-phase system.

Harmonics in a Three-Phase System

Consider a three-phase system that has well balanced loads but has a third harmonic because of some electronic ballasts used in the fluorescent lighting or some other non-linear loads. The following plot shows the fundamentals of the three phases (the 3 larger sine waves) and the third harmonics (the smaller sine wave). The third harmonic of each of the three phases all lie right on top of each other (they are in-phase), so they show up on the plot below as a single red line.

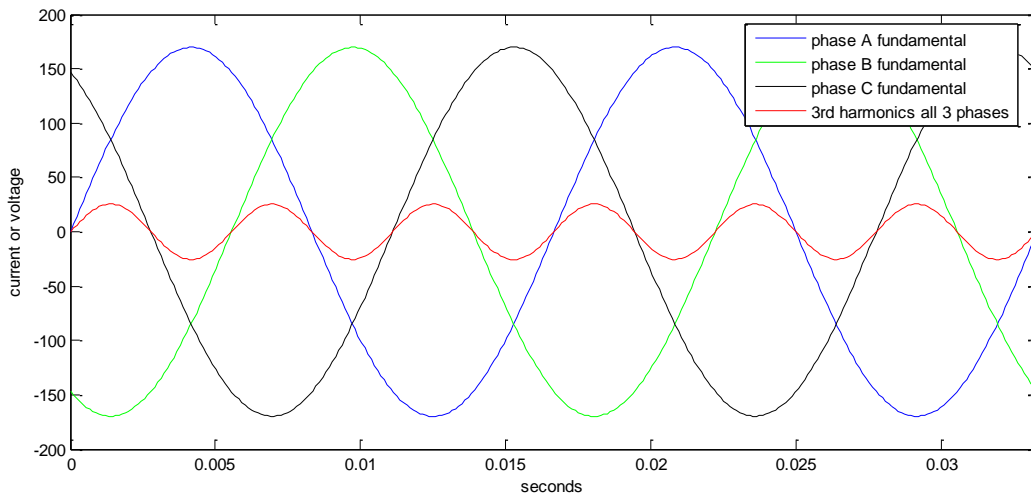

Third Harmonic of All Three Phases Adds In-Phase

Although in this well-balanced system there is no zero-sequence energy at the fundamental frequency, at the third harmonic frequency all of energy adds in-phase, which is just another way of saying that all of the 3rd harmonic energy goes into the zero-sequence phasors. Remember that zero-sequence energy results in excess current (and heat) on the neutral wire, potentially overheating the wire and associated

terminations. This condition could potentially be detected with thermography before it led to significant risk of fire.

All harmonics that are integer multiples of three are also “zero-sequence harmonics” (3rd, 6th, 9th, etc). These are also called “triplen harmonics”. These harmonics tend to decrease in amplitude as they go up in frequency, so the 3rd harmonic is usually the worst.

Other undesirable things happen with the second harmonic.

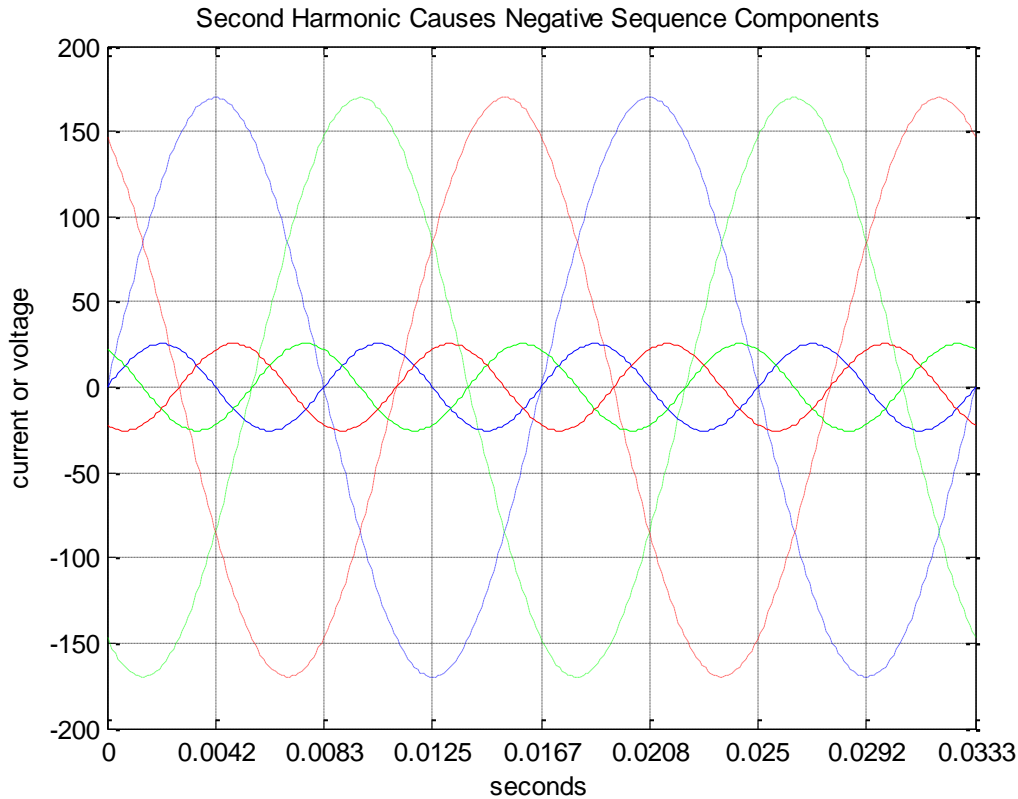

3-Phase: Dashed Lines Represent the Fundamental, Solid Lines the 2nd Harmonic

On the plot above, the fundamental frequency waves are represented by the dashed lines. Notice that the sequence of the peaks, traveling from left to right on the plot is blue, green, red. However, if you look at the 2nd harmonics (represented by the smaller solid line waves) you will notice that the order is blue, red, green. The fact that the sequence is reversed means that the 2nd harmonic is a “negative-sequence” harmonic. The 5th, 8th, 11th, etc. harmonics are also negative-sequence harmonics. The even harmonics are typically close to zero in amplitude so that the 2nd harmonic is usually very small. The higher the frequency the lower the magnitude tends to be, so the first odd negative-sequence harmonic (the 5th harmonic) tends to be the most disruptive.

Remember that negative-sequence harmonics produce motor torque that works against the desired rotation of the motor, wasting energy that manifests as excess heat potentially identifiable with an IR camera.

Variable Frequency Drives

Variable speed (also called “variable frequency”) motor drives (VFDs) typically use a pulse width modulated (PWM) voltage to control the speed of a motor. The pulses out of a typical PWM module are shown in blue in the figure below. The red line is the integral of the pulses, meant to be an approximation to a sine wave.

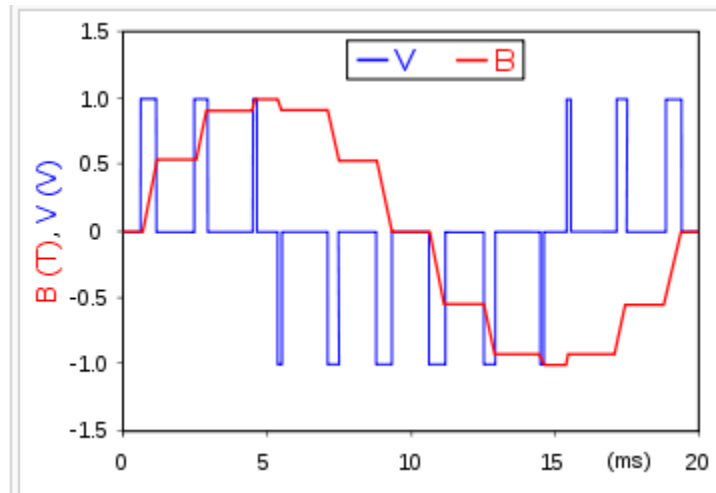

Output of a Pulse Width Modulator (PWM) Used in a Variable Frequency Drive (VFD)ⁱⁱⁱ

Because the red waveform is not a pure sine wave, we have harmonics. The relative amplitudes of the harmonics caused by the motor drive typically look something like the following.

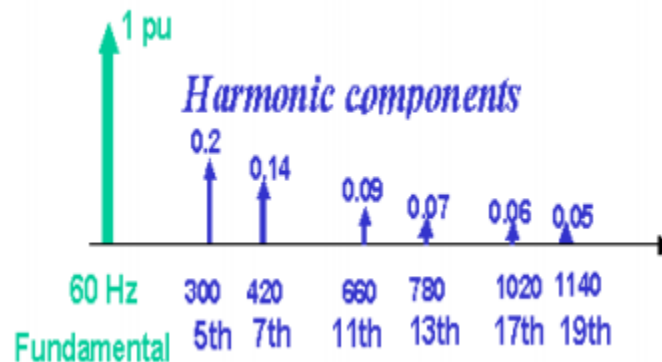

Harmonic Components of a Typical VFD^{iv}

VFD’s such as the one described above do not produce a third harmonic component or any triplen harmonics, but that 5th and 11th harmonics are negative sequence harmonics and therefore manifest as

reverse torque.^v Once again, a disciplined program of periodic thermographic surveys may catch problems due to negative sequence harmonics caused by VFD's and allow one to take corrective action such as the installation of harmonic filters.

Transformers

Transformers use iron cores to contain the magnetic fields essential to their operation. Stray currents called "eddy currents" are undesirable electric currents that circulate in the iron core to varying degrees depending on the design of the transformer. These eddy currents waste energy and produce heat in the iron core. Eddy currents increase in proportion to the square of the frequency, so that in a transformer designed for 60 Hertz, higher frequency harmonics may cause significant heating of the core. Besides wasting energy these eddy currents could cause safety problems due to overheating.^{vi}

"Hysteresis" in a transformer core refers to the fact that the magnetic field lags the energizing current in time. Hysteresis losses are worse at higher frequencies, so harmonics cause additional hysteresis loss.

Skin effect in the conductors of a transformer cause an additional "copper loss" at higher harmonic frequencies.

Some transformers are designed to operate in the presence of significant harmonics. These are called "K-rated transformers". The higher the K-rating, the more harmonics the transformer can handle.

These three factors: eddy current losses, hysteresis losses and skin effect losses can be big problems for transformers subjected to harmonics. All three problems result in excess heat, therefore they can be detected with a properly designed program of periodic thermographic inspection.

Conclusion

Thermography is fast becoming a valuable troubleshooting tool for electricians. However, the electrician armed with an IR camera will not be fully effective until he or she combines thermography with in-depth knowledge of the often subtle problems caused by power quality and harmonics issues.

AVO Training Institute (<http://www.avotraining.com/>) offers courses in Thermal Imaging and Power Quality & Harmonics.

References

ⁱ https://en.wikipedia.org/wiki/Fourier_series

ⁱⁱ https://en.wikipedia.org/wiki/Symmetrical_components gives a more in-depth treatment of the method of symmetrical components.

ⁱⁱⁱ https://en.wikipedia.org/wiki/Pulse-width_modulation

^{iv} <http://www.ab.com/support/abdrives/documentation/techpapers/Harmonicsbasics.pdf>

^v <http://www.ab.com/support/abdrives/documentation/techpapers/Harmonicsbasics.pdf>

^{vi} Power Quality Measurement and Troubleshooting, Glen A. Mazur, Second Edition, pages 136 - 139